

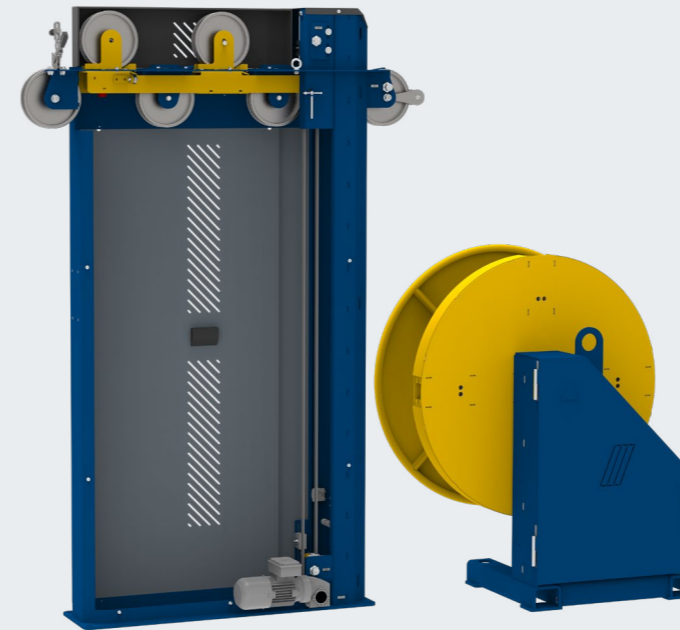

Sund Birsta Strap Accumulator

Accumulator

Quicker strap change while improving safety

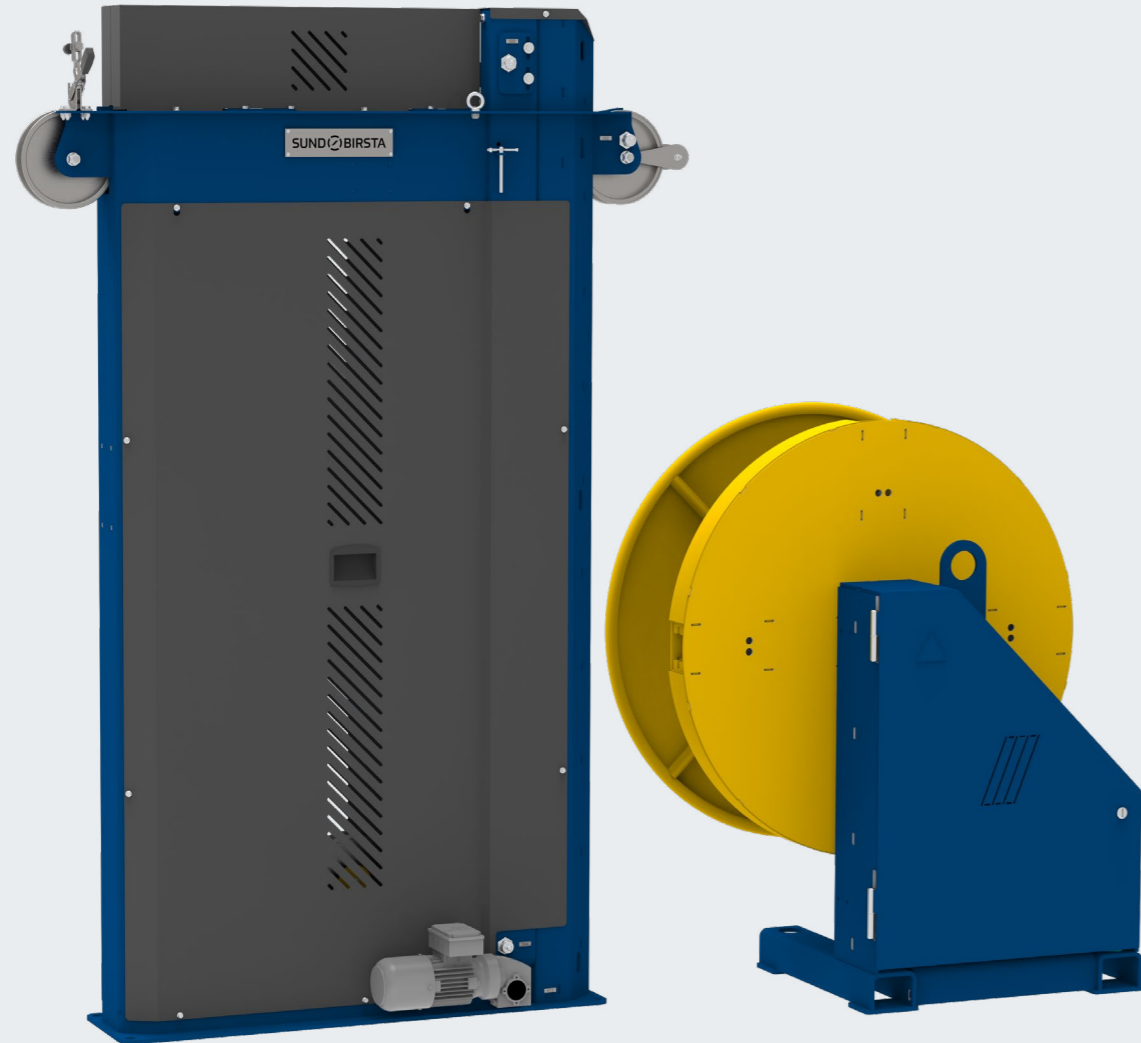

Straight path design

The accumulator wheels are positioned in the upper feeding location, allowing the strap to be fed easily in a straight line through the accumulator wheels and into the strapping unit.

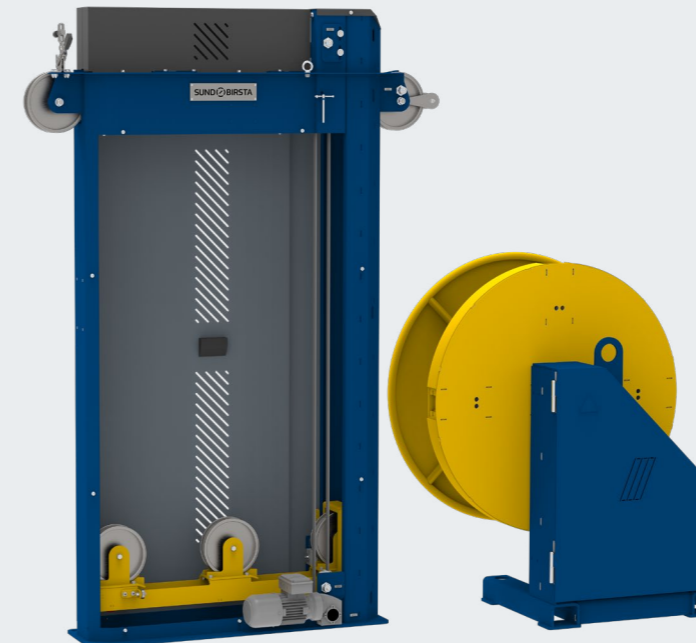

Smooth feeding and strapping

When in use, the accumulator wheels move vertically to accommodate the surplus strap.

Sund Birsta Accumulator

The accumulator advancements in ergonomics and the quicker feeding through a straight strap path design has improved efficiency of the feeding processes. This ensures quicker loading and feeding of strap while improving operator safety.

The accumulator design have safety features, concealing moving parts of the accumulator and the strap thus reducing the risk for the operator.

The accumulator are compatible with all 32 mm strapping machines and coil compactors that are equipped with strapping units, making it a versatile and essential tool for a wide range of industrial applications. It is designed for jumbo coils of 32 mm wide strap with a max capacity of 1000 Kg.



Long lifetime

The design of the accumulator makes it reliable and durable.



Easy to use

The accumulator is easy to use as it has the straight strap path design and ergonomic features which makes the feeding process much easier.



Safe design

The accumulator has all moving parts concealed to prevent accidents and ensures user safety.

We increase your productivity.

sundbirsta.com

SUND  BIRSTA

CS0106_240709